

# ABOUT ME

- Kyaw Htet
- Head of Intelligent and Network Operations
- [kyawhtet@agbcommunication.com](mailto:kyawhtet@agbcommunication.com)



# THINGS NETWORK (IoT)

# IoT Historical

**Industry 1.0**  
1760-1840

**Industry 2.0**  
1870-1914

**Industry 3.0**  
1960-2000

**Industry 4.0**  
2010-Present



Steam  
First industrial revolution by the introduction of water and steam power to drive the machine

Electricity  
Became mass production, and factories became more efficient with electric

Electronics  
Computer, automated process. PLC

Digital/Cloud  
Smart automation with IoT, AI, Cloud, Big Data

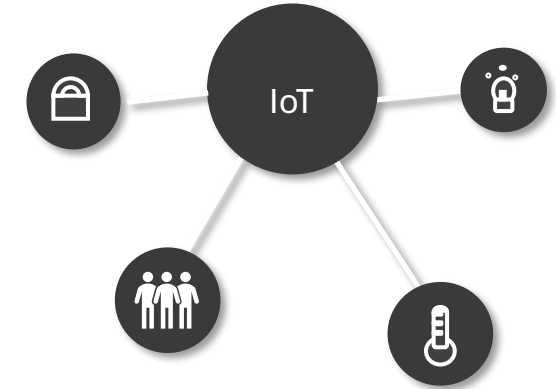

IoT means “making things smart by giving them the ability to communicate over the internet”

# What is the Internet of Things (IoT)?

# HOW IoT WORKS

- ▲ Sensor collects the data
- ▲ Data is transmitted to edge/cloud(IoT platform)
- ▲ Data is proceeded by edge/cloud.
- ▲ Action to actuators (on/off, notification)

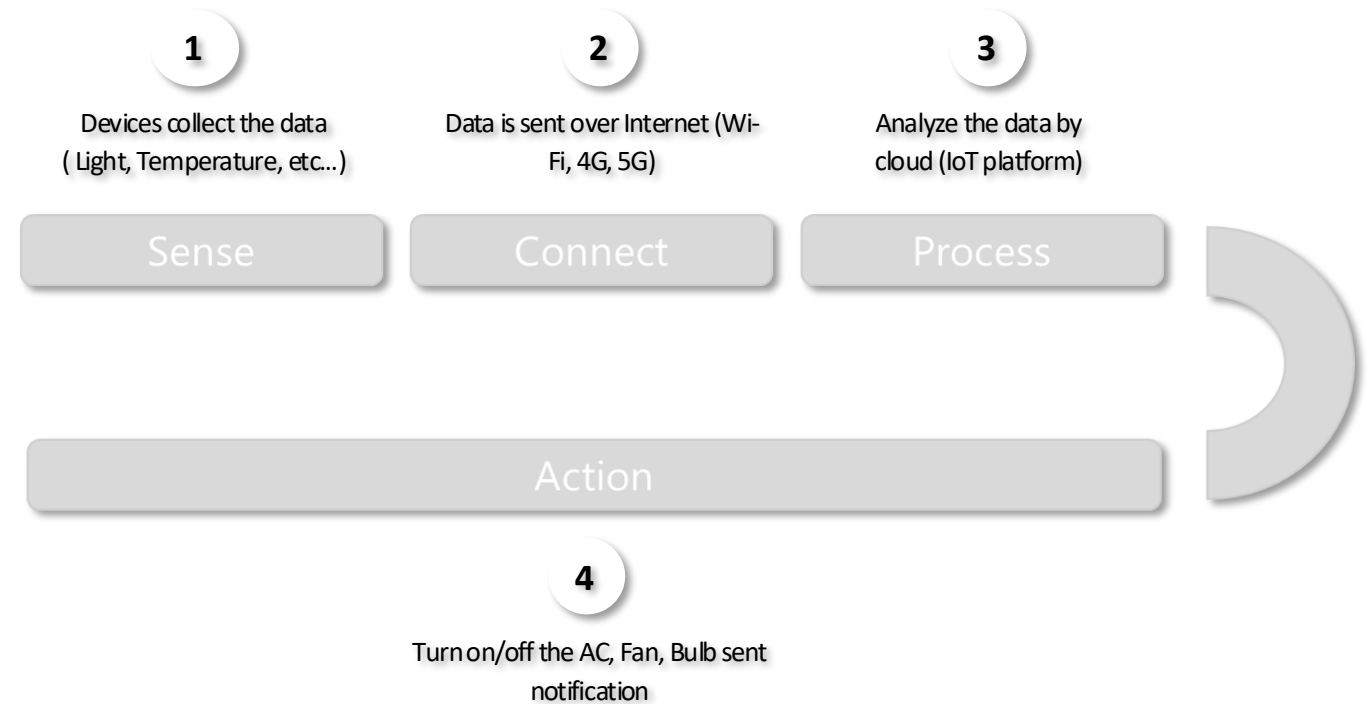

# Components of IoT

---

A Senor, Actuator and gateway

A Connectivity

A Data Processing

A Application & Action

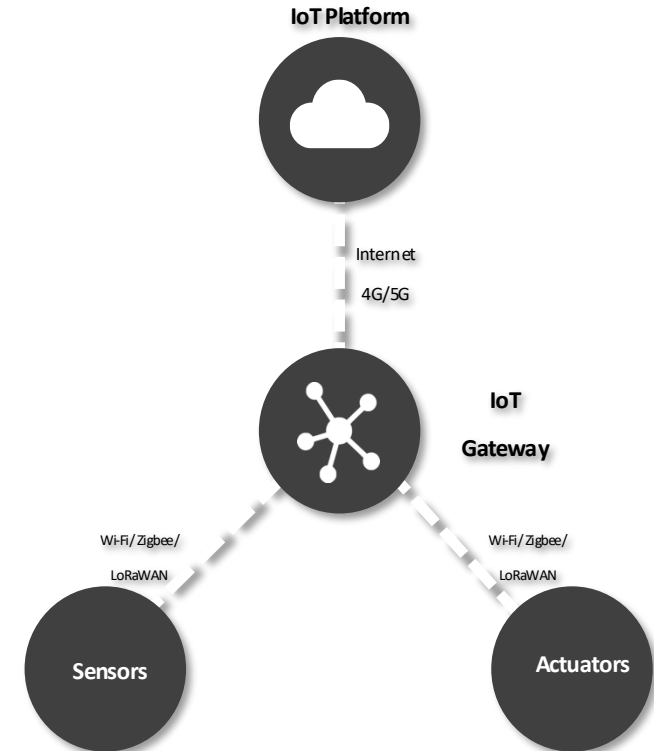

# Sensors & Actuators

## ➤ Sensors



Temperature Sensor



Humidity Sensor



CO<sub>2</sub> Sensor



GPS Sensor



Soil moisture sensor

## ➤ Actuators



Switch



Valve control

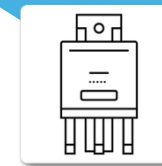

Relay switch



Buzzer

# Sensors



Temperature Sensor



Humidity Sensor



CO<sub>2</sub> Sensor

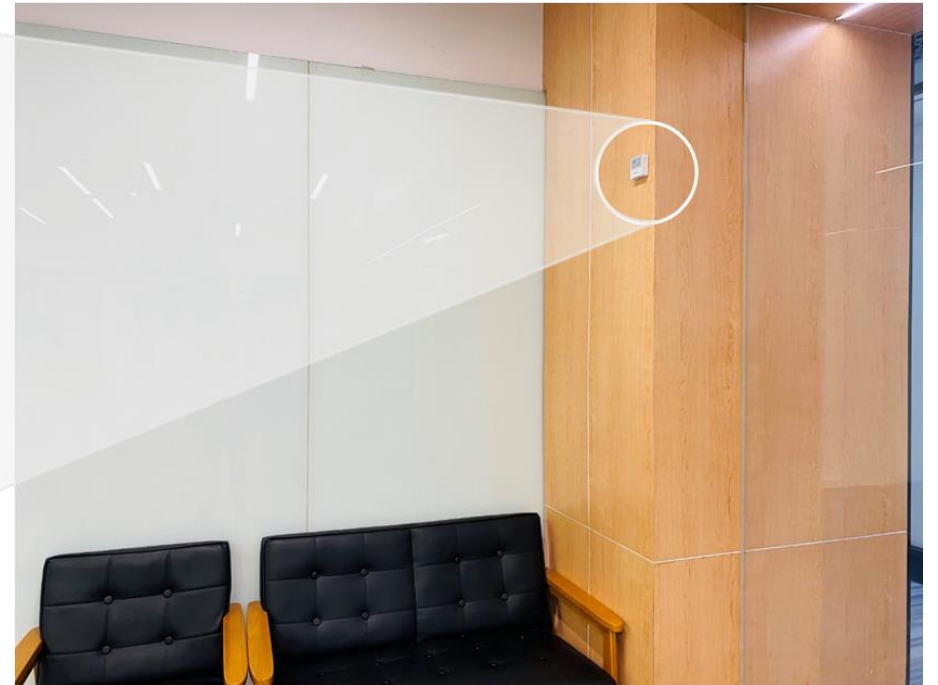
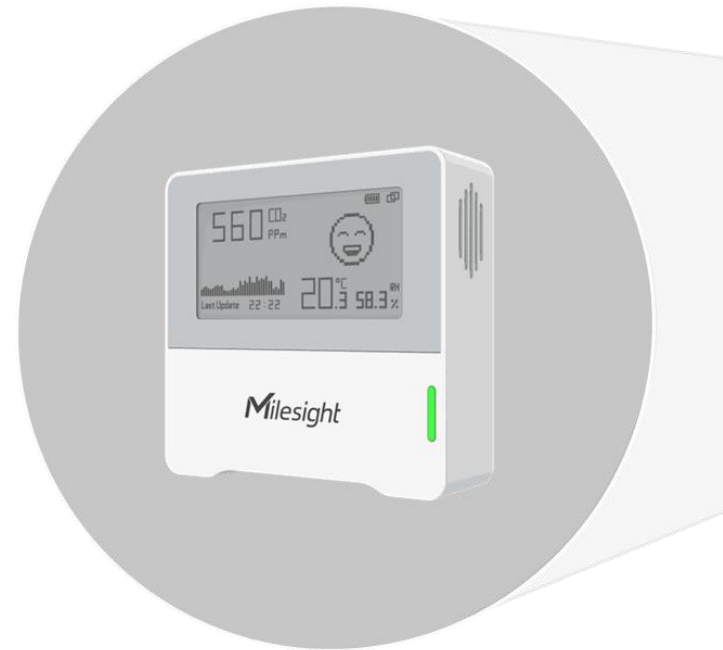

# Actuators

## Smart Wall Switch

 Remote ON/OFF

 Time-Based ON/OFF

 Power Consumption Measurement



# Actuators

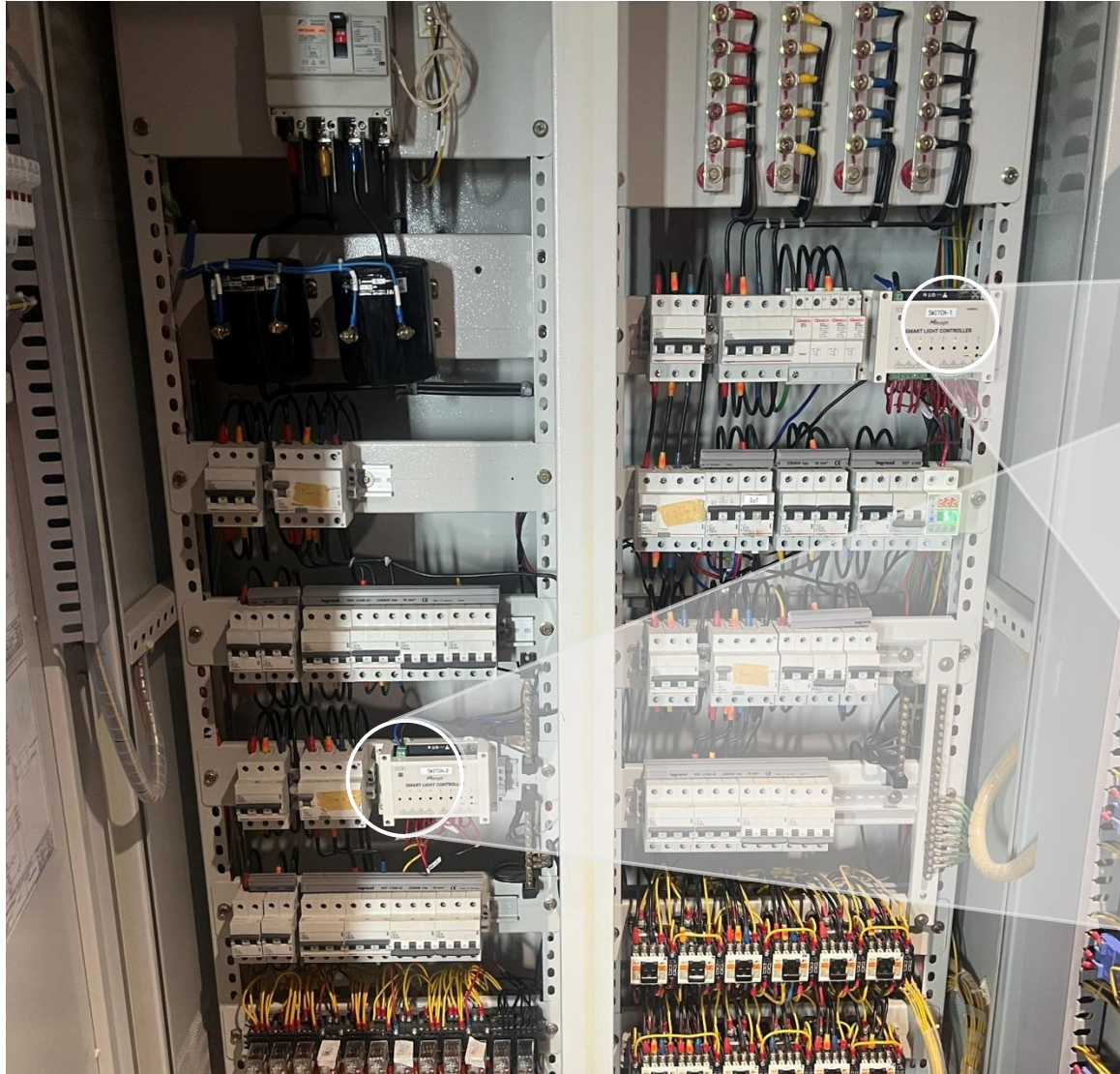

“ Control heavy compressors with relay breaker ”



# Actuators



“ Continuous monitoring and control to PLC with Modbus ”



Feature	Wi-Fi	Zigbee	LoRaWAN
Range	Short-Medium (10-100m)	Short (10-100m)	Very Long (2-15 km+)
Header size	80-150 bytes	25-60 bytes	13-17 bytes
Max Bandwidth	50-1000 Mbps	20-250 Kbps	0.3-50 Kbps (slow!)
Frequency	2.4 GHz / 5 GHz	2.4 GHz / 915 MHz / 868 MHz	Sub-GHz (868/915 MHz)
Power Use	High (needs frequent charging)	Low (months/years)	Ultra-Low (10+ years!)
Topology	Star	Mesh	Star-of-Star
Max Devices	~30-50 per router	65,000+ (mesh helps)	Thousands (per gateway)
Latency	Low (ms)	Low (ms)	High (seconds-minutes)
Use Case	Video streaming, web	Smart home (lights, sensors)	Agriculture, utilities, long-range sensors

## Connectivity

# Data Processing



## Edge Processing

Near devices & Sensors

- ❖ Real-time control & fast response
- ❖ Local filtering & data aggregation
- ❖ Reduces bandwidth & cloud costs



## Cloud Processing

Centralized infrastructure

- ❖ Massive data ingestion & storage
- ❖ Predictive and Analytics with Machine Learning
- ❖ Global visualization, dashboards and centralize control

# Application & Actions



## Application

- Web Dashboards
- Mobile Apps
- Voice Assistants
- APIs for Custom Development



## Action & Automation

- Alerts: Push Notifications, SMS, Email
- Workflows & Automation Rules (IF → THEN)
- Automated Actuator Control
- Scheduled Operations

# Demo setup for IAQ sensor integration with IoT Platform

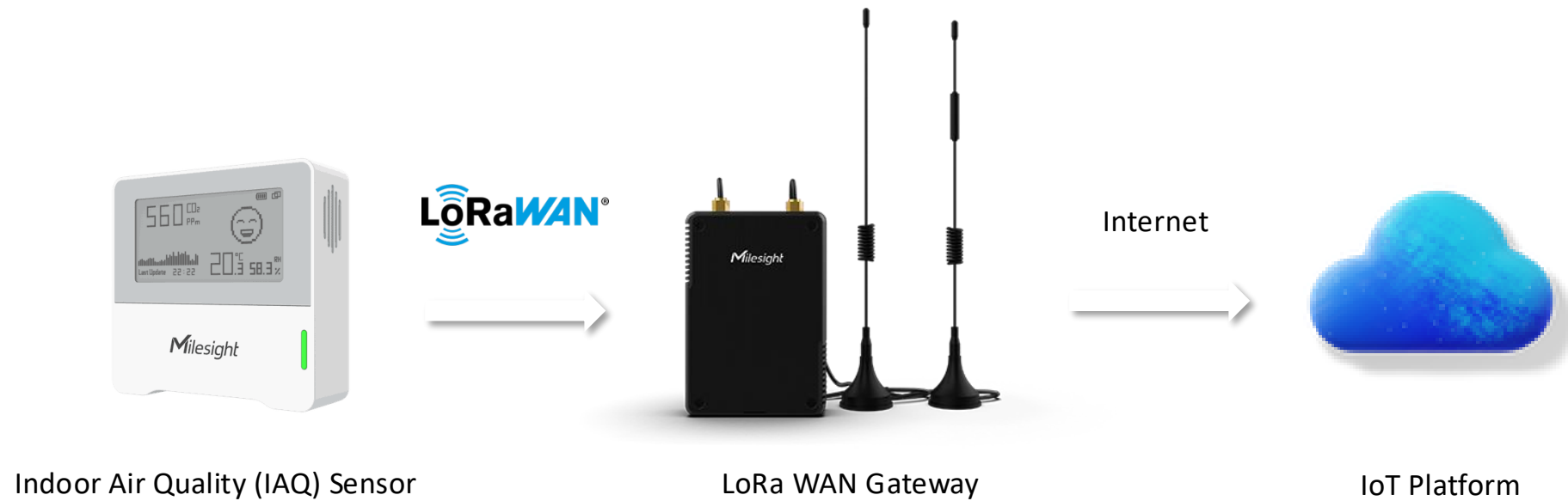

# IoT Sensor Setup Overview

## IoT Sensor Setup Process

- ❖ Get the app (milesight toolbox) and scan NFC to extract information for below
- ❖ Check hardware version, firmware version and get EUI code
- ❖ Check class type (Class A)
- ❖ Reporting interval (default 20min)

# Gateway Device Setup Overview

## Gateway Device Setup Process

- ❖ Enable embedded server
- ❖ Create application for your IoT sensor (Device name and description)
- ❖ Setup device setting and add EUI for IoT sensor (class type, EUI, payload decode, device application key)
- ❖ Setup nodeRED with device Access token from IoT Platform after creating device profile.

# IoT Platform Setup Overview

## IoT Platform Setup Process

- ❖ Get account (<https://thingsboard.cloud>)
- ❖ Create Device profile and Device for IoT sensor and gateway (access token)
- ❖ Create rule chain for IoT sensor and Gateway (Telemetry and attribute)
- ❖ Create application dashboard for data monitoring using telemetry data from IoT devices

# IoT Sensor Setup Overview

Get IoT sensor information using Milesight ToolBox App , available on App store and Play store (Need NFC function in phone)

Software upgrade  
| Device reset setting

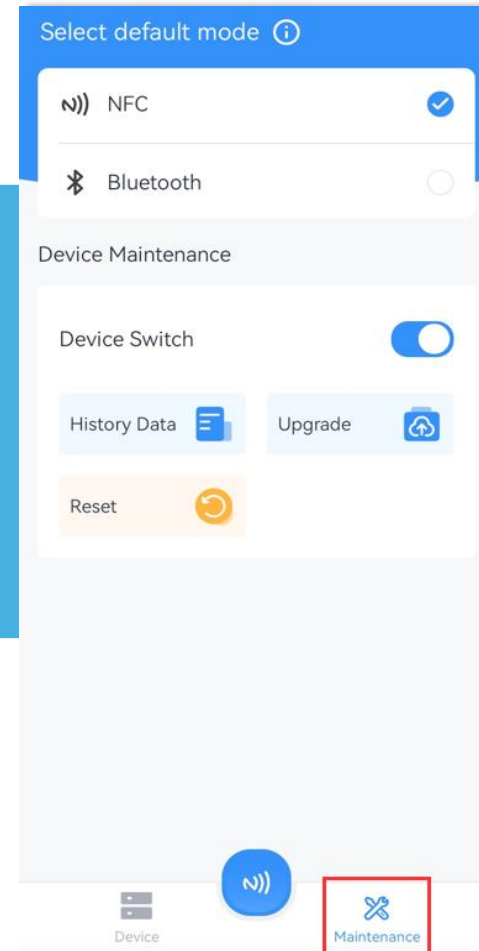
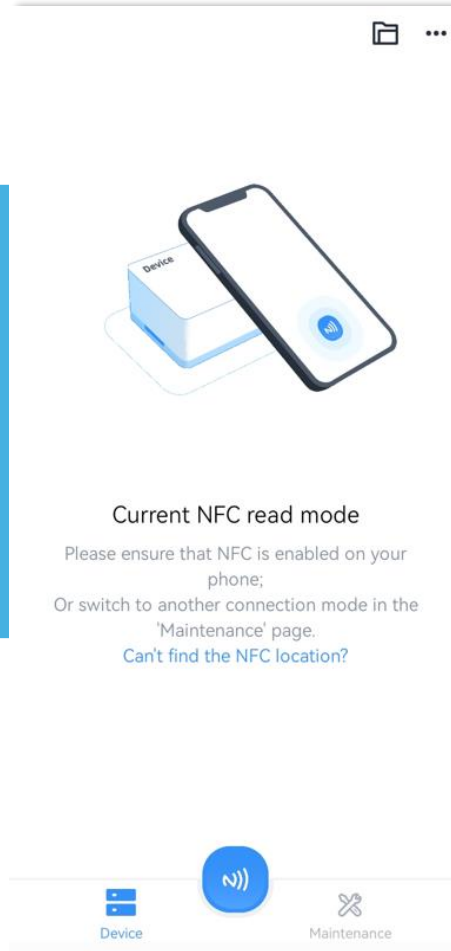

# IoT Sensor Setup Overview

- Get EUI
- Check Firmware Version
- Check Hardware Version

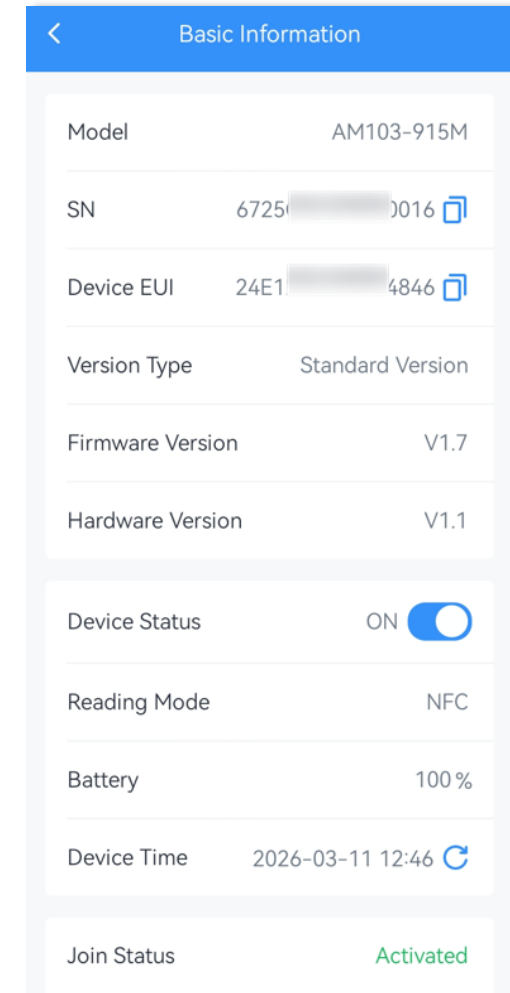
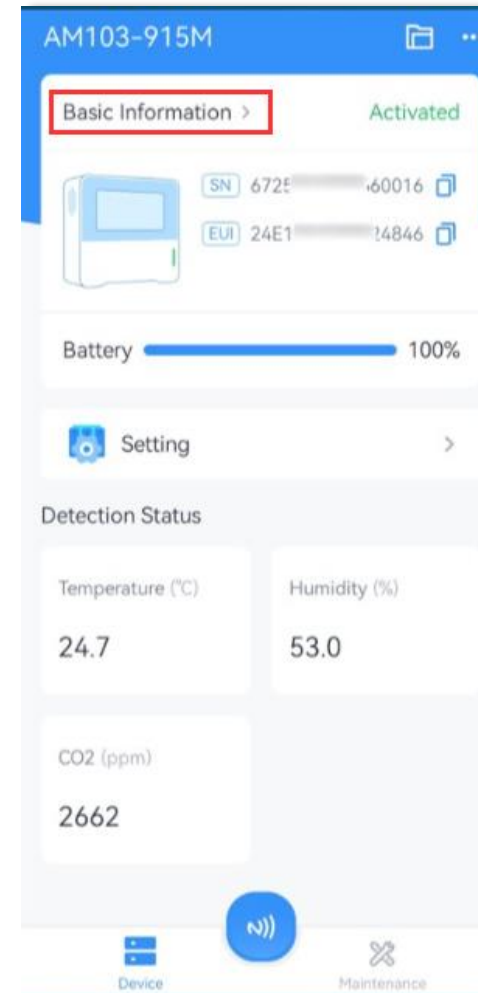

# IoT Sensor Setup Overview

- Setup Reporting Interval
- Check Class Type  
(sensor class default type A)

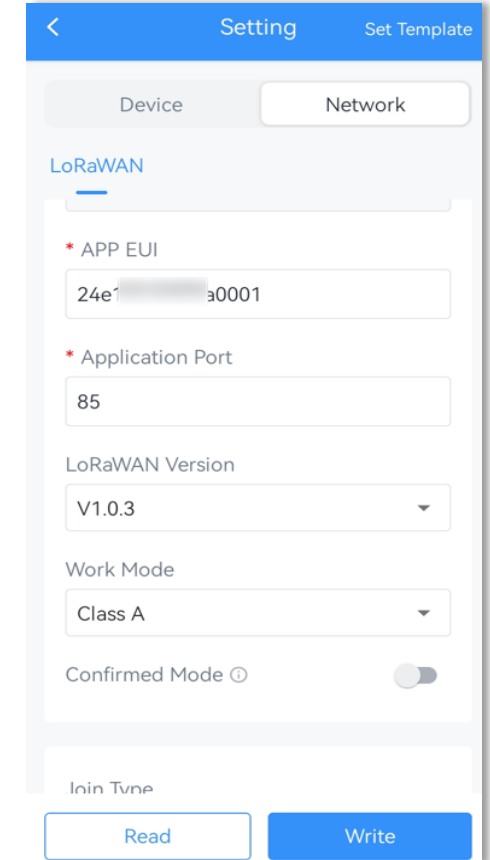
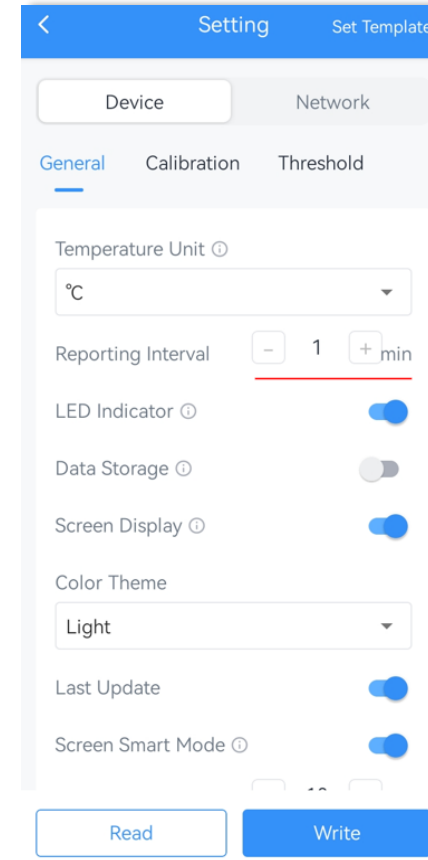
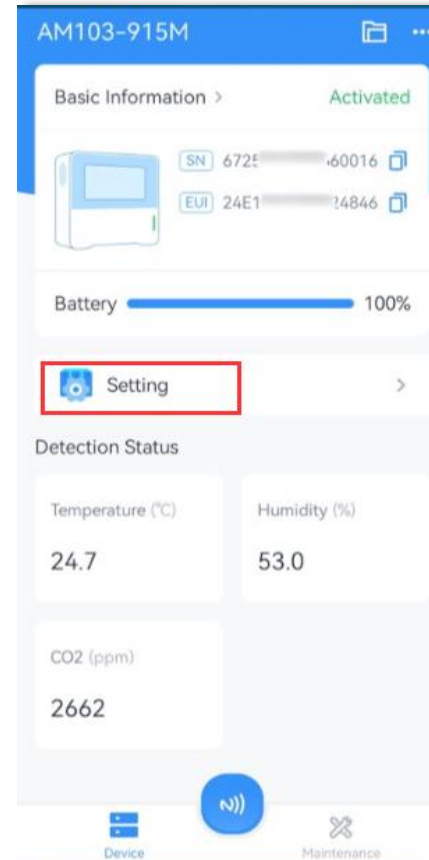

# Gateway Device Setup Overview

- Find and connect Gateway SSID
- Default IP "192.168.1.1" and login (username – xxxx, password – xxxx)
- Enable embedded network server from “Disabled/Disconnected” state to “Enable/Connected” state

The screenshot shows the configuration page for a Packet Forwarder. The 'General' tab is selected. Under 'General Setting', Gateway EUI is 2-347B0 and Gateway ID is 2-347B0. Frequency-Sync is Disabled. Data Retransmission is unchecked. The 'Multi-Destination' table is as follows:

ID	Enable	Type	Server Address	Connect Status	Operation
0	Disabled	Embedded NS	localhost	Disconnected	[Edit] [Delete] [Add]



Enable

Type

Server Address

MQTT Port

Multi-Destination

ID	Enable	Type	Server Address	Connect Status	Operation
0	Enabled	Embedded NS	localhost	Connected	[Edit] [Delete] [Add]

# Gateway Device Setup Overview

ID	Name	Description	Operation
1	WS502-915M-544	2 gang switch	
5	AM103-915M-846	IAQ Sensor	

- Create “Applications” corresponding to device names

- When create the name of application and device, use device model number and last 3-num of EUI

Type	Operation
MQTT	

Save Cancel

# Gateway Device Setup Overview

Update Payload Codec for each device by clicking obtain button

Status

Packet Forwarder

**Network Server**

Protocol Integration ▶

Network ▶

System ▶

Maintenance ▶

General Applications **Payload Codec** Profiles Device FUOTA Multicast Groups

Gateway Fleet Packets

### Inbuilt Payload Codec Library

Library Version **1.5.30**

Obtaining Type

**Obtain**

Note: Ensure that the Internet access is available.

Name	Payload Decoder Function	Payload Encoder Function	Object Mapping Function	Details
AM102	✓	✓	✓	!
AM102L	✓	✓	✓	!

# Gateway Device Setup Overview

Add IoT Device by using EUI code, Application name and make them "Online"

The interface shows a navigation sidebar on the left with the following items: Status, Packet Forwarder, Network Server (highlighted), Protocol Integration, and Network. The main content area has a top navigation bar with tabs: General, Applications, Payload Codec, Profiles, Device (highlighted), FUOTA, and Multicast Groups. Below the tabs, there are sub-sections for Gateway Fleet and Packets. The 'Device' section is active, displaying a toolbar with buttons: Add (highlighted), Bulk Import, Delete All, and Export All. A search bar is located to the right of the toolbar. Below the toolbar is a table with the following data:

Device Name	Device EUI	Device-Profile	Payload Codec	Application	Last Seen	Status	Operation
AM103-915M-846	24E1-██████-4846	ClassA-OTAA	AM103L	AM103-915M-846	6 minutes ago	Online	

**AM103-915M-846**

Device Name	<input type="text" value="AM103-915M-846"/>
Description	<input type="text" value="IAQ Sensor"/>
Device EUI	<input type="text" value="24E 24846"/>
Device-Profile	<input type="text" value="ClassA-OTAA"/>
Application	<input type="text" value="AM103-915M-846"/>
Payload Codec	<input type="text" value="AM103L"/>
fPort	<input type="text" value="85"/>
Frame-counter Validation	<input checked="" type="checkbox"/>
Application Key	<input type="radio"/> Default Value <input checked="" type="radio"/> Custom Value
	<input type="text" value="5572404c696e6b4c6f52613230"/>
Device Address	<input type="text" value="073f4f1c"/>
Network Session Key	<input type="text" value="f850678433c55cb282b9b8ea36"/>
Application Session Key	<input type="text" value="de56aa732d0fd1118796c0fae2c"/>
Uplink Frame-counter	<input type="text" value="9"/>
Downlink Frame-counter	<input type="text" value="4"/>
Timeout	<input type="text" value="1440"/> min

# Gateway Device Setup Overview

When adding IoT device, the following information are needed to add

# Gateway Device Setup Overview

Check in Packets whether the device can send uplink or not

Status	General	Applications	Payload Codec	Profiles	Device	FUOTA	Multicast Groups
Packet Forwarder	Gateway Fleet	Packets					
Network Server	Send Data To Device						
	Device EUI	Type	Payload	Port	Confirmed		

24E1	4846	24E1	M7B0	923400000	SF7BW125	-/-	0	2	DnUnc	2026-03-09 04:21:45Z	!
24E1	4846	24E1	M7B0	923400000	SF7BW125	-65/13.5	14	3	UpUnc	2026-03-09 04:21:45Z	!

# Gateway Device Setup Overview

For Node-RED, “Enable” and “Launch” → Save  
(Node-RED is to transmit sensors data into IoT platform)

The screenshot displays the configuration interface for Node-RED on a gateway device. The left sidebar contains a menu with the following items: Packet Forwarder, Network Server, Protocol Integration, Network, System, Maintenance, APP, and Python. The 'Node-RED' option is highlighted in blue and has a red box around it. The main content area is titled 'Node-RED' and contains the following settings:

- Enable:** A checkbox is checked, and a red box is drawn around it. A 'Launch' button is also highlighted with a red box.
- SSL Access:** A checkbox is checked.
- Node-RED Version:** 3.0.2
- Node Library Version:** 1.0.13
- Upgrade Node Library:** A text input field is empty, with 'Browse' and 'Upgrade' buttons to its right.
- All Flows:** An 'Export' button is present.
- Restore Factory Defaults:** A 'Reset' button is present.
- Save:** A blue 'Save' button is located at the bottom of the configuration area.

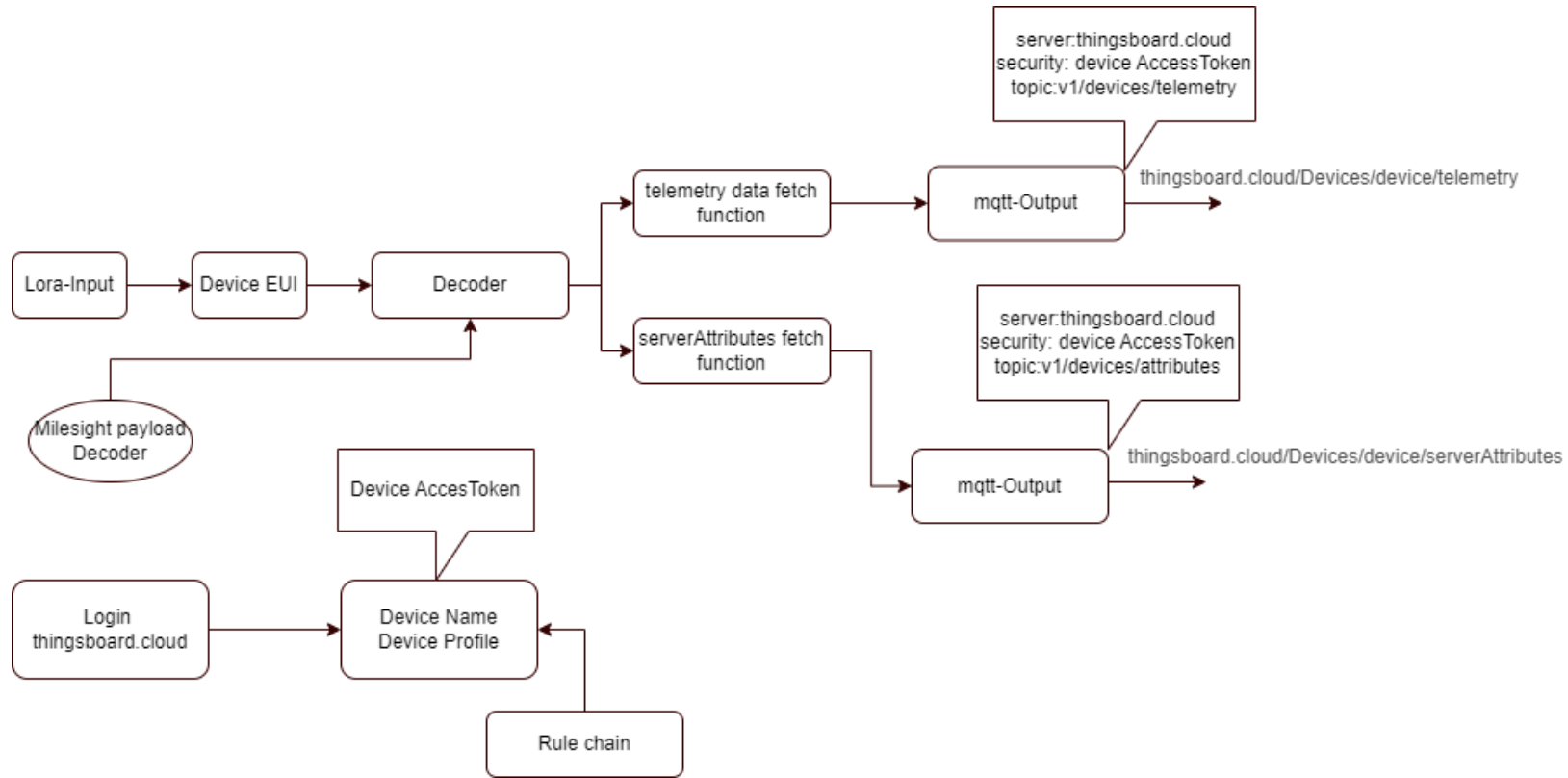

## Flow of Node-RED and IoT Platform

# Gateway Device Setup Overview

In Node-RED, add sensor device EUI

Edit Device Filter node

Delete Cancel Done

Properties

Name AM103-915M-846

Device EUI 24E12 24846 +

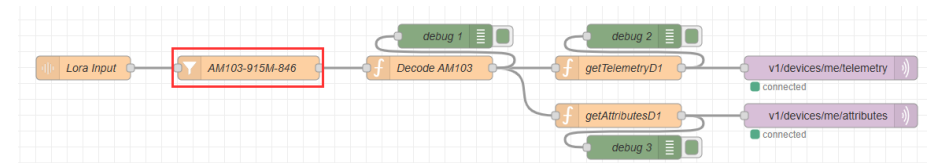

# Gateway Device Setup Overview

- Get the decoder for the supported IoT device series from **Milesight's GitHub** and code is JS.
- [Link: SensorDecoders/am-series at main · Milesight-IoT/SensorDecoders · GitHub](#)
- Add decoder code into Node-RED
- Verify return message at below

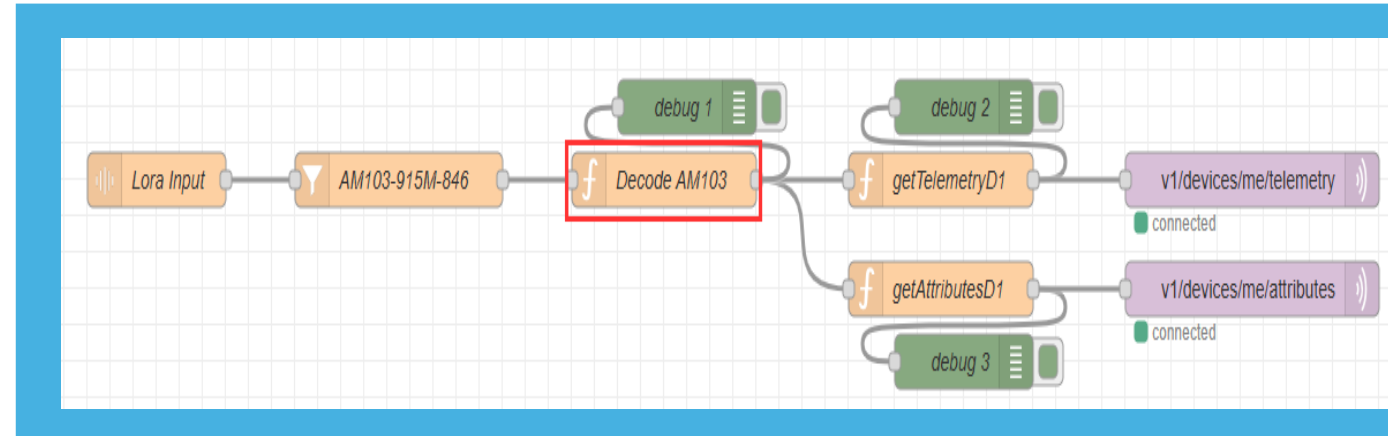

“

```
// On Message
```

```
var bytes = msg.payload; // incoming bytes array from MQTT or HTTP
```

```
msg.payload_1 = milesightDeviceDecode(bytes); // decode AM103 payload
```

```
msg.payload = msg.payload_1;
```

”

```
return msg;
```

# Gateway Device Setup Overview

“Add telemetry data”

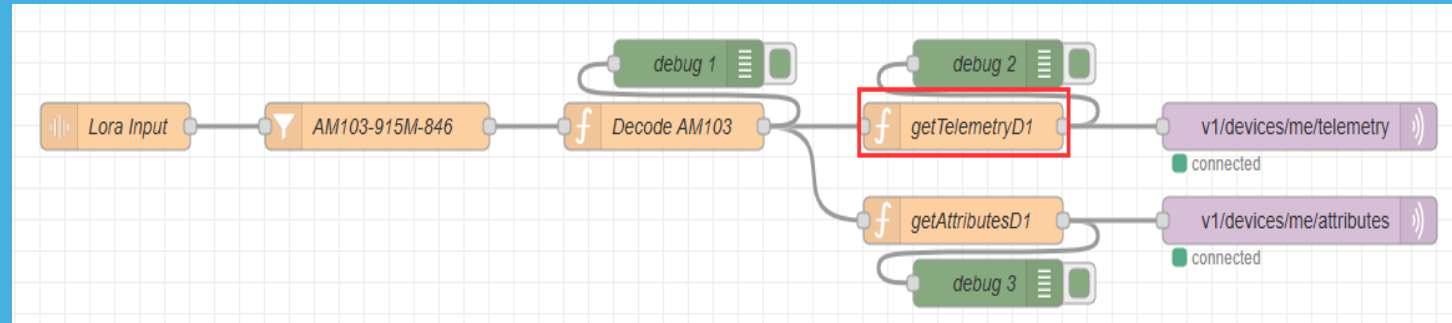

```
var device_1 = {  
  devEUI: msg.object.devEUI,  
  deviceName: msg.object.deviceName,  
  temperature: msg.object.temperature,  
  humidity: msg.object.humidity,  
  co2: msg.object.co2,  
  battery: msg.object.battery  
};
```

```
msg.payload = { device_1 };  
return msg;
```

# Gateway Device Setup Overview

COMMUNICATION

## “Add attributes data”

```
var dr= msg.dr;
var adr = msg.adr;
var freq = msg.freq;
var snr = msg.snr;
var rssi = msg.rssi;
var time = msg.time;
var fport = msg.fport;
var fcnt = msg.fcnt;
var deveui = msg.deveui;
var server_attr_1 = {
  dr,adr,freq,snr,rssi,fport,fcnt,deveui
}
```

```
msg.payload = {server_attr_1};
return msg;
```

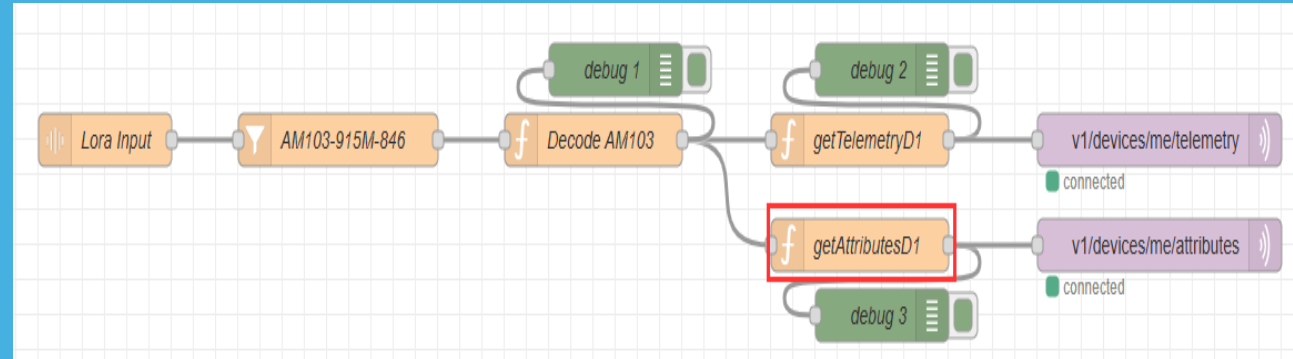

# Gateway Device Setup Overview

System Flow of LoRaWAN IoT  
Application with Node-RED

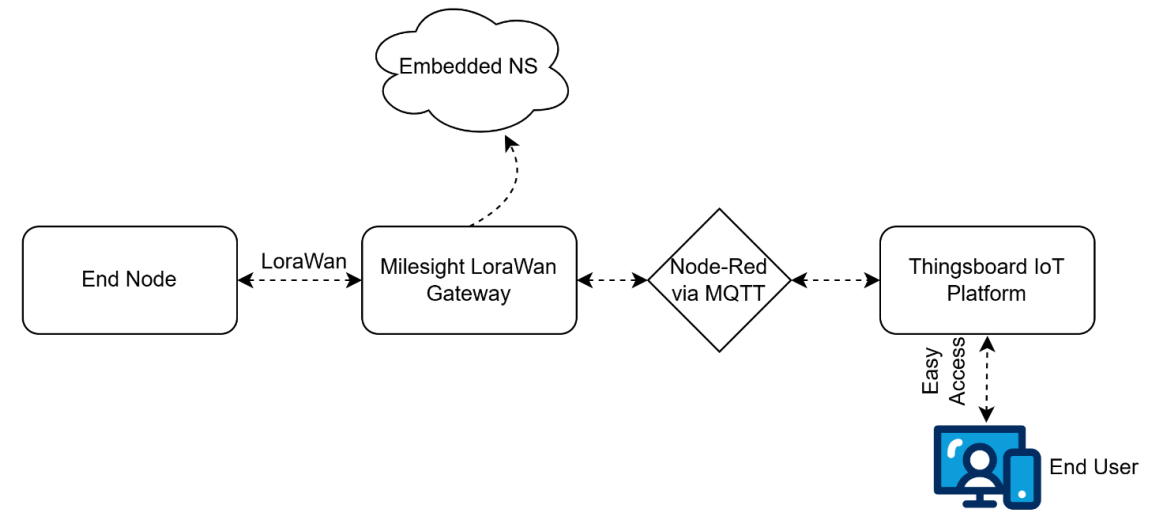

## Gateway Device Setup Overview

For telemetry >>> add server url, topic and security

**Edit mqtt out node**

Delete Cancel Done

**Properties**

Server 1 mqtt.thingsboard.cloud:1883 3

Topic 2 v1/devices/me/telemetry

QoS 0 Retain

Name Name

Tip: Leave topic, qos or retain blank if you want to set them via msg properties.

**Properties**

Name Name

**Connection** Security Messages

Server mqtt.thingsboard.cloud Port 1883

Connect automatically

Use TLS

Protocol MQTT V3.1.1

Client ID Leave blank for auto generated

Keep Alive 60

Session  Use clean session

**Properties**

Name Name

Connection **Security** Messages

Username HyMirPsx8gYNOKu62a8F Access Token of Gateway from Thingsboard

Password

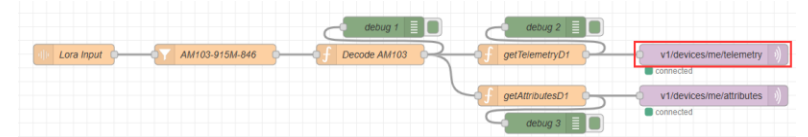

## Gateway Device Setup Overview

For attributes >>> add server, topic and security

**Edit mqtt out node**

Delete Cancel Done

**Properties**

Server 1 mqtt.thingsboard.cloud:1883 3

Topic 2 v1/devices/me/attributes

QoS 0 Retain

Name Name

Tip: Leave topic, qos or retain blank if you want to set them via msg properties.

**Properties**

Name Name

**Connection** Security Messages

Server mqtt.thingsboard.cloud Port 1883

Connect automatically

Use TLS

Protocol MQTT V3.1.1

Client ID Leave blank for auto generated

Keep Alive 60

Session  Use clean session

**Properties**

Name Name

Connection **Security** Messages

Username HyMirPsx8gYN0ku62a8F Access Token of Gateway from Thingsboard

Password

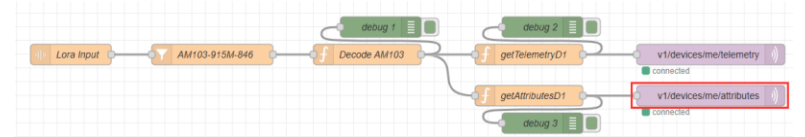

# IoT Platform Setup Overview

Get access token of gateway

Home Alarms Dashboards Reporting NEW Solution templates Entities **Devices**

All Groups

Devices   Include customer entities

<input type="checkbox"/>	Created time ↓	Name	Device profile	Label
<input type="checkbox"/>	2026-01-22 09:19:09	Gateway-Workshop	gateway-Workshop	
<input type="checkbox"/>	2026-01-10 13:35:29	WS503-915M-682	WS503-915M-682	MST_WS503SW_Smartoffice



< Details Attributes Latest telemetry Calculated fields

Open details page Manage credentials Manage owner and groups

Delete device

Copy device Id **Copy access token**

HTTP **MQTT** CoAP

Use the following instructions for sending telemetry on behalf of the device using shell

**Windows** MacOS Linux Docker

**Install necessary client tools**

Use the instructions to download, install, setup and run mosquitto\_pub [Documentation](#)

**Execute the following command**

```
mosquitto_pub -h smart.agb.com.mm -p 1883 -t v1/devices/me/telemetry -u "HyM1rF"
```



< Details Attributes Latest telemetry Calculated fields Alarms Events

Open details page Manage credentials Manage owner and groups **Check connectivity**

Delete device

# IoT Platform Setup Overview

Add rule chain
?
✕

Name\* ← Name Gateway or Devices

Debug mode

Description

Cancel
Add

Create Rule Chain for IoT Device and Gateway

Sensor device Rule Chain

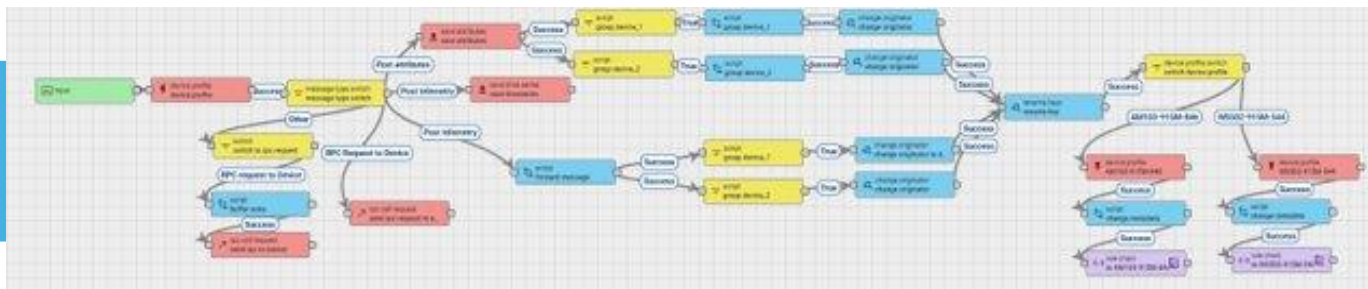
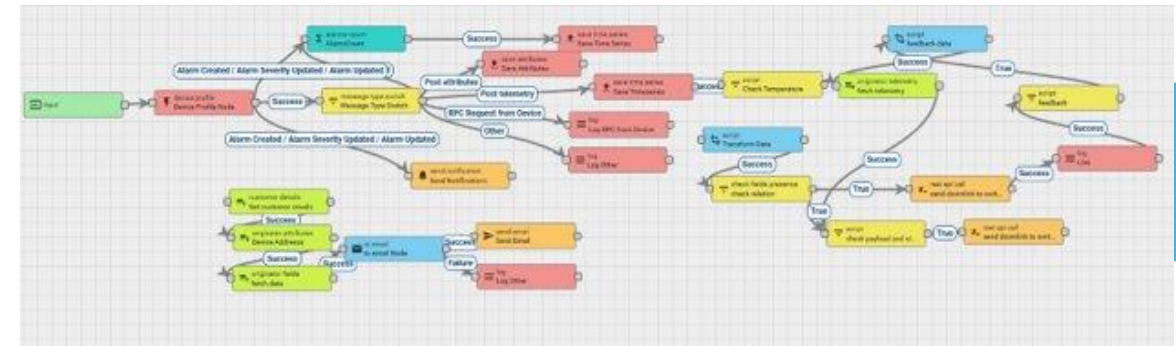

Gateway Rule chain

# IoT Platform Setup Overview

## Create Device Profile and Device

The screenshot shows the 'Add device profile' form with a progress bar at the top containing four steps: 1. Device profile details, 2. Transport configuration (Optional), 3. Alarm rules (0) (Optional), and 4. Device provisioning (Optional). The first step is active. Two red boxes with arrows point to the 'Name\*' field and the 'Default rule chain' dropdown menu. The text 'Setup Device Profile Name' and 'Use Device Rule chain' are placed to the right of the arrows.

Add Device Profile and select preconfig rule chain

Add Device and select profile

The screenshot shows the 'Add new device' form with a progress bar at the top containing two steps: 1. Device details and 2. Credentials (Optional). The first step is active. Three red boxes with arrows point to the 'Name\*' field, the 'Label' field, and the 'Device profile\*' dropdown menu. The text 'Setup Device Name' and 'Use Device Profile' are placed to the right of the arrows. The dropdown menu shows 'default' as the selected option.

## IoT Platform Dashboard Overview

Go to "Dashboards" ==>

Click "+" sign ==>

Choose "Create new Dashboard"

==> Name for "Title", "Description"

==> Click "Add"

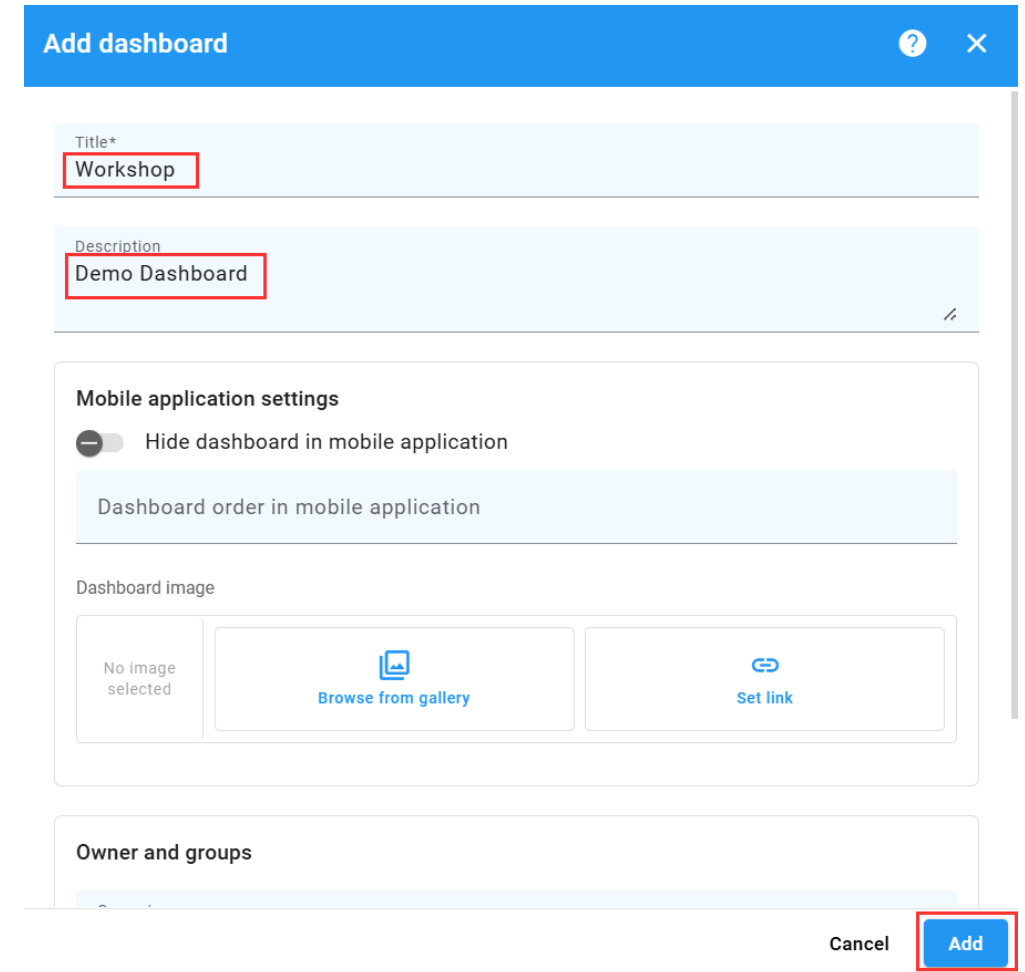
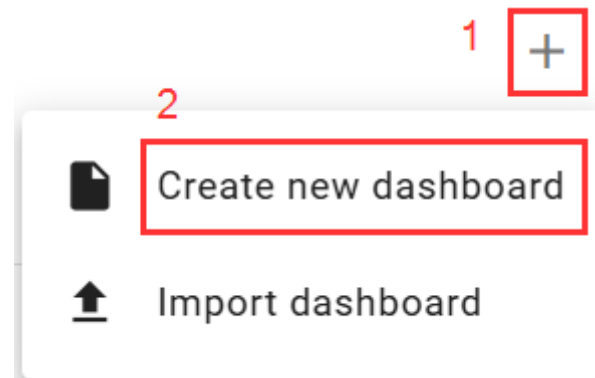
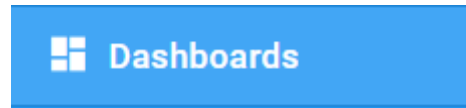
A "Add dashboard" form with a blue header. It contains several sections: "Title\*" with the value "Workshop" in a red box; "Description" with the value "Demo Dashboard" in a red box; "Mobile application settings" with a toggle for "Hide dashboard in mobile application" and a "Dashboard order in mobile application" field; "Dashboard image" with a "No image selected" box, a "Browse from gallery" button, and a "Set link" button; and "Owner and groups" with a partially visible field. At the bottom right are "Cancel" and "Add" buttons, with the "Add" button highlighted in a red box.



## IoT Platform Dashboard Overview

Click "Add new widget"

==> Click "search" icon

==> Type "Temperature"

==> Select Widget

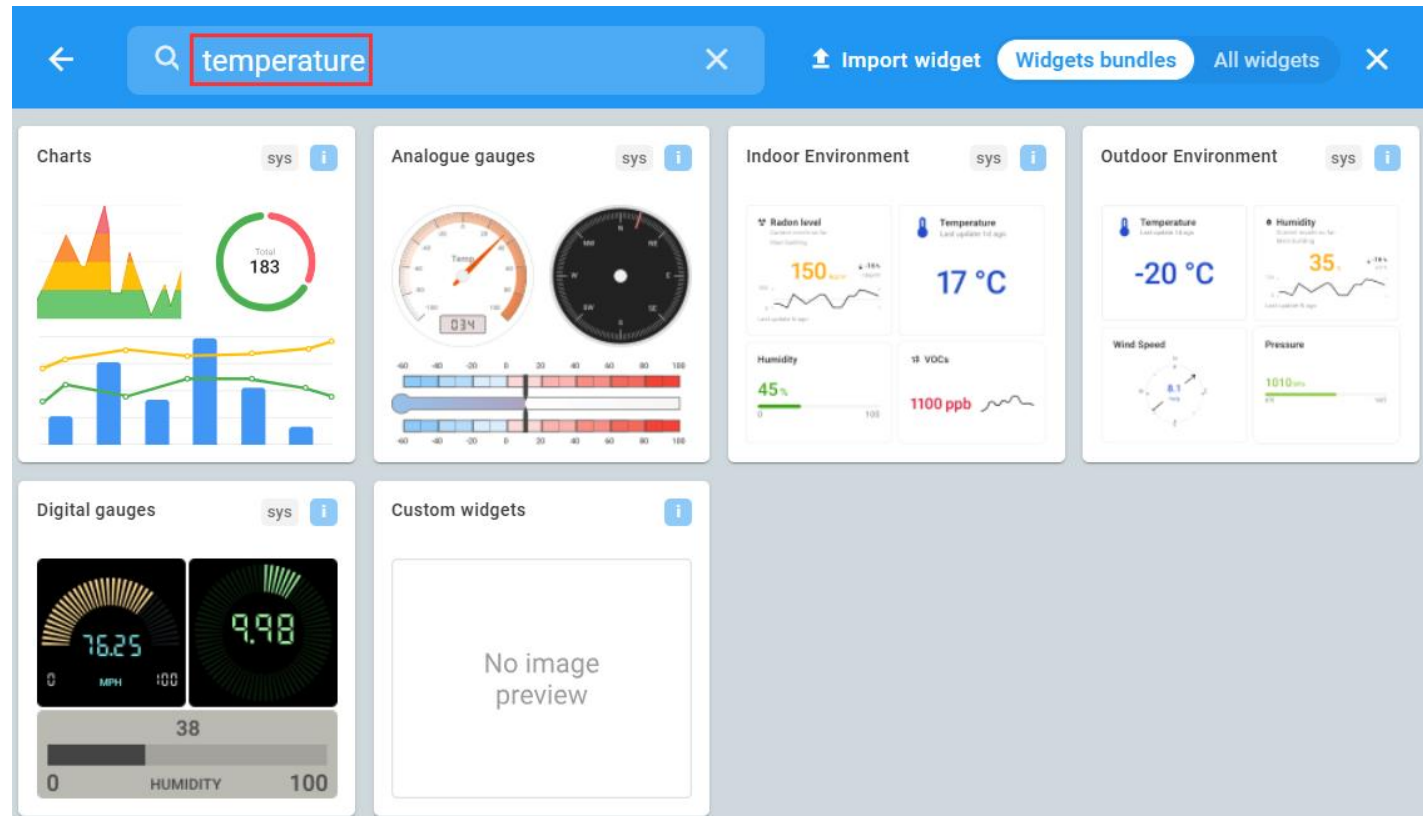

## IoT Platform Dashboard Overview

Choose your device name in "Device"

Choose your timeseries data in "Data Key"

And click "Add"

### Add widget: Indoor temperature card with background

Basic Advanced ? X

**Datasource** Device Entity alias

Device\*  
AM103-915M-846 X

Data key\*  
temperature X

**Appearance**

Layout Square

Auto scale

Cancel Preview **Add**

## IoT Platform Dashboard Overview

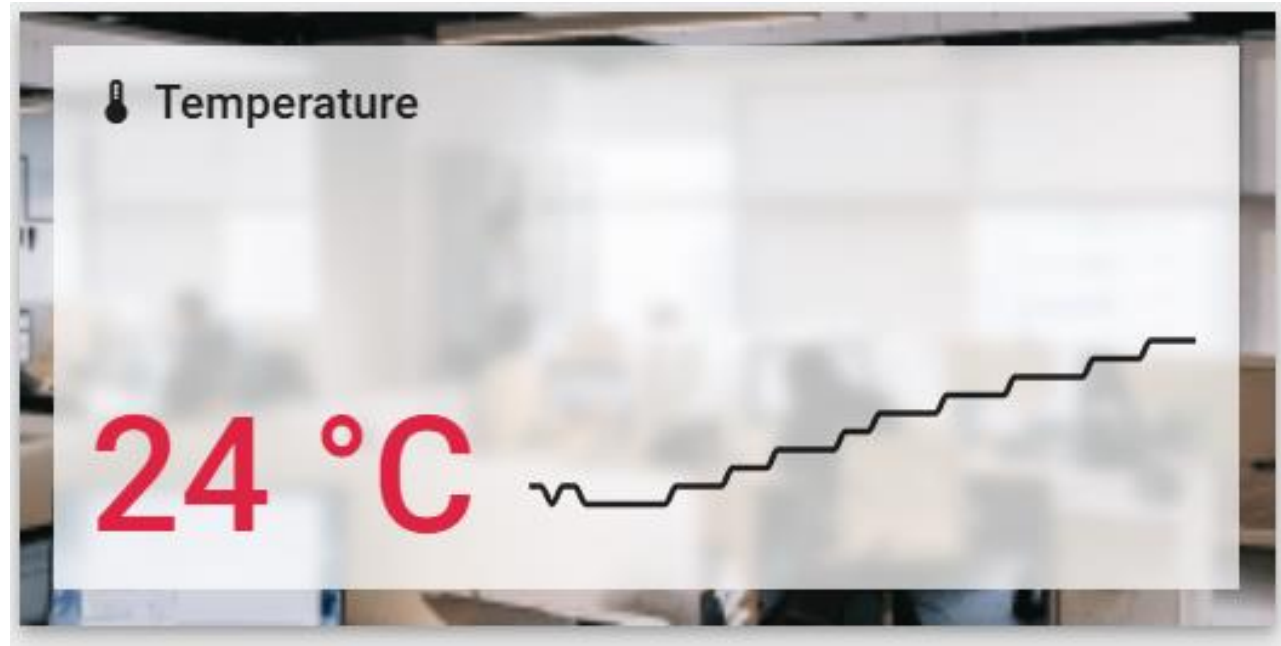

Now get temperature value that display current timeseries data.

Click "save".



## IoT Platform Dashboard Overview

And add another widget that shows  
with chart for temperature.

### Time series chart

Time series chart

Basic Advanced ? X

Preview Decline Apply

**Time window** Use dashboard time window Use widget time window

Display time window Realtime - last 1 minute

**Datasource** Device Entity alias

Device\* AM103-915M-846

**Series** Series Comparison

Key	Label	Type	Y axis	Color	Units	Decimals
tempera...	Temperature		default		°C	0

Add series



## IoT Platform Dashboard Overview

To enable full screen and data export, change to "Advanced" mode , go to "Widget card" , name for "Title" , enable button for full screen and data export.

Click "Apply".

The screenshot shows the configuration interface for a "Temperature Chart" widget. The interface is divided into several sections:

- Header:** "Temperature Chart" with the subtitle "Time series chart". It includes "Basic" and "Advanced" tabs, with "Advanced" selected and highlighted by a red box. There are also help and close icons.
- Configuration Tabs:** "Data", "Appearance", "Widget card" (selected and highlighted by a red box), "Actions", and "Layout".
- Buttons:** "Preview", "Decline", and "Apply".
- Card title section:**
  - A toggle switch for "Display widget title" is turned on.
  - A text input field for "Title" contains "Temperature Chart" and is highlighted by a red box.
  - A "Title Tooltip" input field contains the text "Set".
- Card buttons section:**
  - A toggle switch for "Enable fullscreen" is turned on.
  - A toggle switch for "Enable data export" is turned on.

## IoT Platform Dashboard Overview

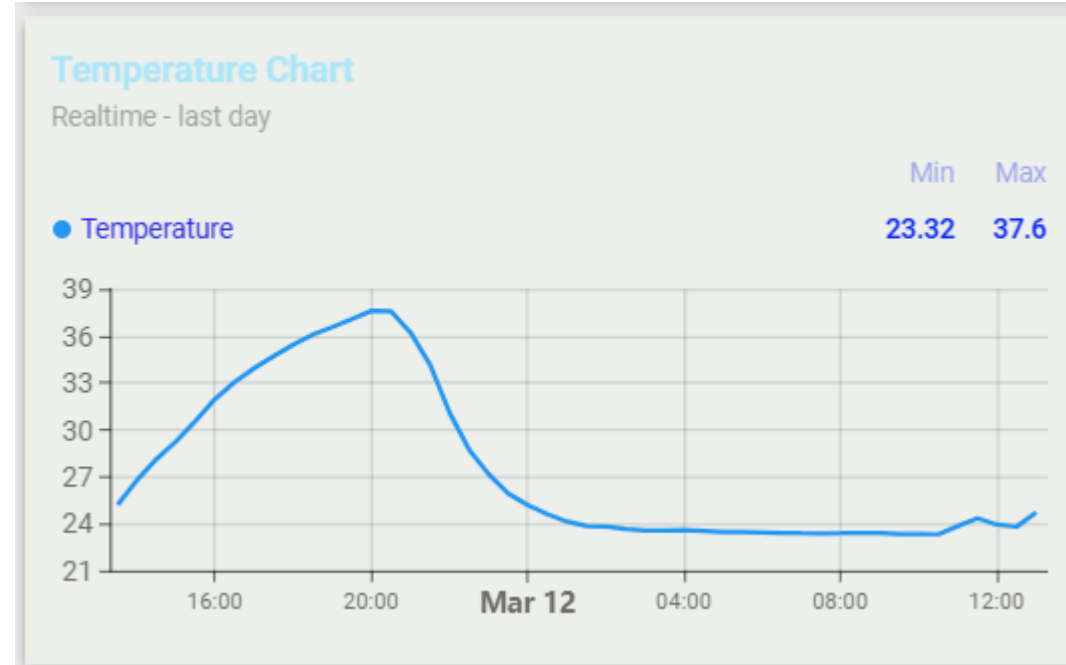

Realtime
History

Realtime
History

**Time window**

Last
  Relative

UTC+06:30

1 day ▼

**Time window**

Last
  Range
  Relative

UTC+06:30

1 day ▼

When get the temperature chart, can check the old timeseries data and export the report by selecting the time and date.

### IoT Platform Dashboard Overview

Choose the time, date and grouping interval.

Realtime **History**

**Time window**

Last **Range** Relative UTC+06:30

From 04/03/2026, 00:00 To 12/03/2026, 13:03

Aggregation Average

Grouping interval **30 minutes**

Cancel **Update**

### Temperature Chart

History - from 2026-03-04 00:00:00 to 2026-03-12 13:35:51

Min Max  
21.97 37.75

● Temperature



Date	Temperature
Mar 04	21.97
Mar 05	23.5
Mar 06	22.5
Mar 07	23.5
Mar 08	23.5
Mar 09	24.0
Mar 10	23.5
Mar 11	23.5
Mar 12	37.75

## IoT Platform Dashboard Overview

Can export the report by clicking export icon and choosing file type to download.

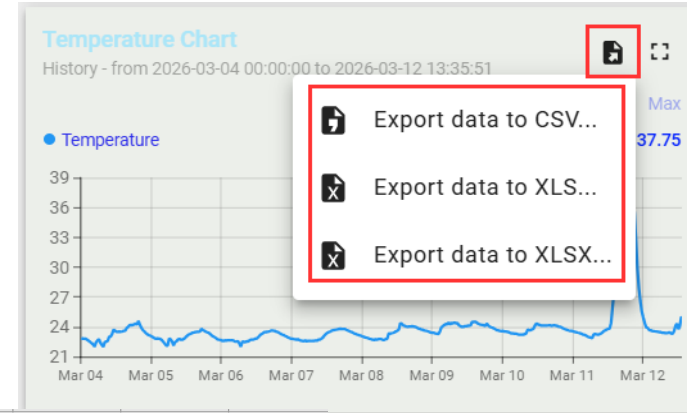

Timestamp	Temperature
2026-03-09 06:15:00	24.36333333
2026-03-09 07:15:00	24.43666667
2026-03-09 08:15:00	24.33333333
2026-03-09 08:45:00	24.14666667
2026-03-09 09:15:00	23.99333333
2026-03-09 09:45:00	23.99333333
2026-03-09 10:15:00	24.04333333
2026-03-09 10:45:00	24.11333333
2026-03-09 11:15:00	24.1
2026-03-09 11:45:00	24.13333333
2026-03-09 12:15:00	24.50333333
2026-03-09 12:45:00	24.46333333
2026-03-09 13:15:00	24.50666667
2026-03-09 13:45:00	24.44
2026-03-09 14:15:00	24.31724138
2026-03-09 14:45:00	
2026-03-09 15:15:00	
2026-03-09 15:45:00	

Custom AutoFilter

Show rows where:

Temperature

is greater than 28

And  Or

Use ? to represent any single character  
Use \* to represent any series of characters

Export

Timestamp	Temperature
2026-03-08 15:15:00	29.03333333

## IoT Platform Dashboard Overview

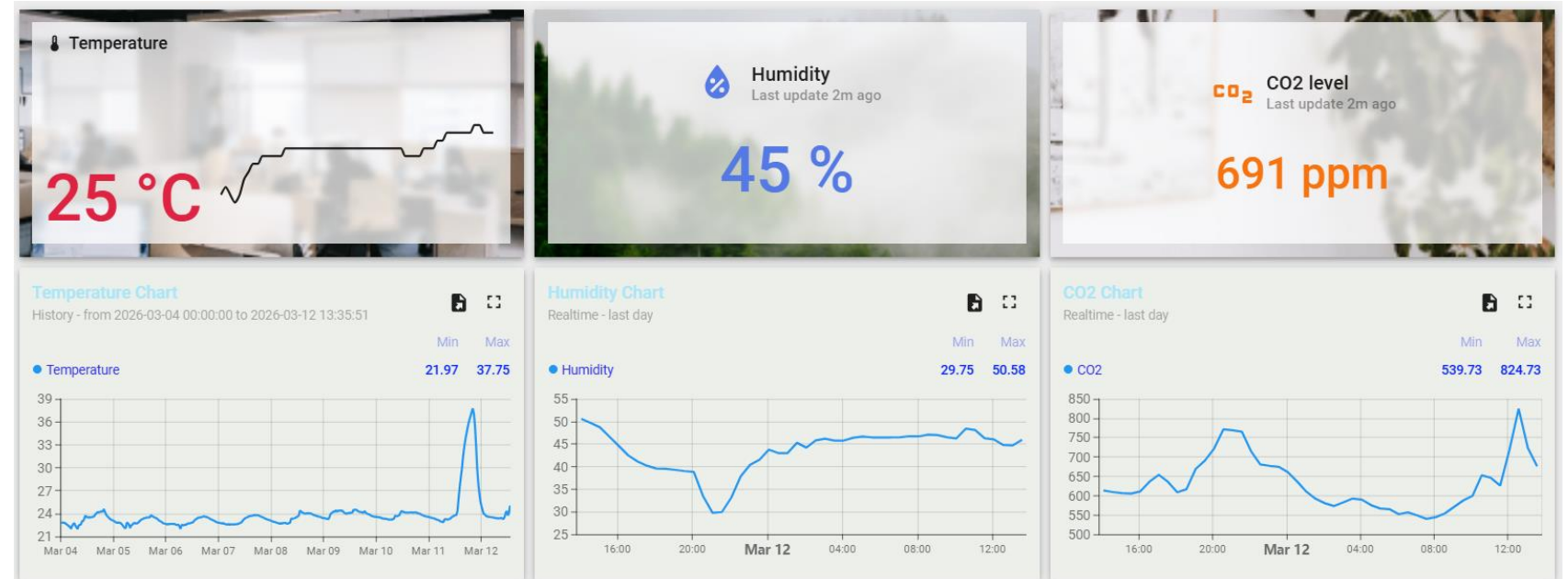

And add widgets for humidity and CO2 timeseries data like temperature.

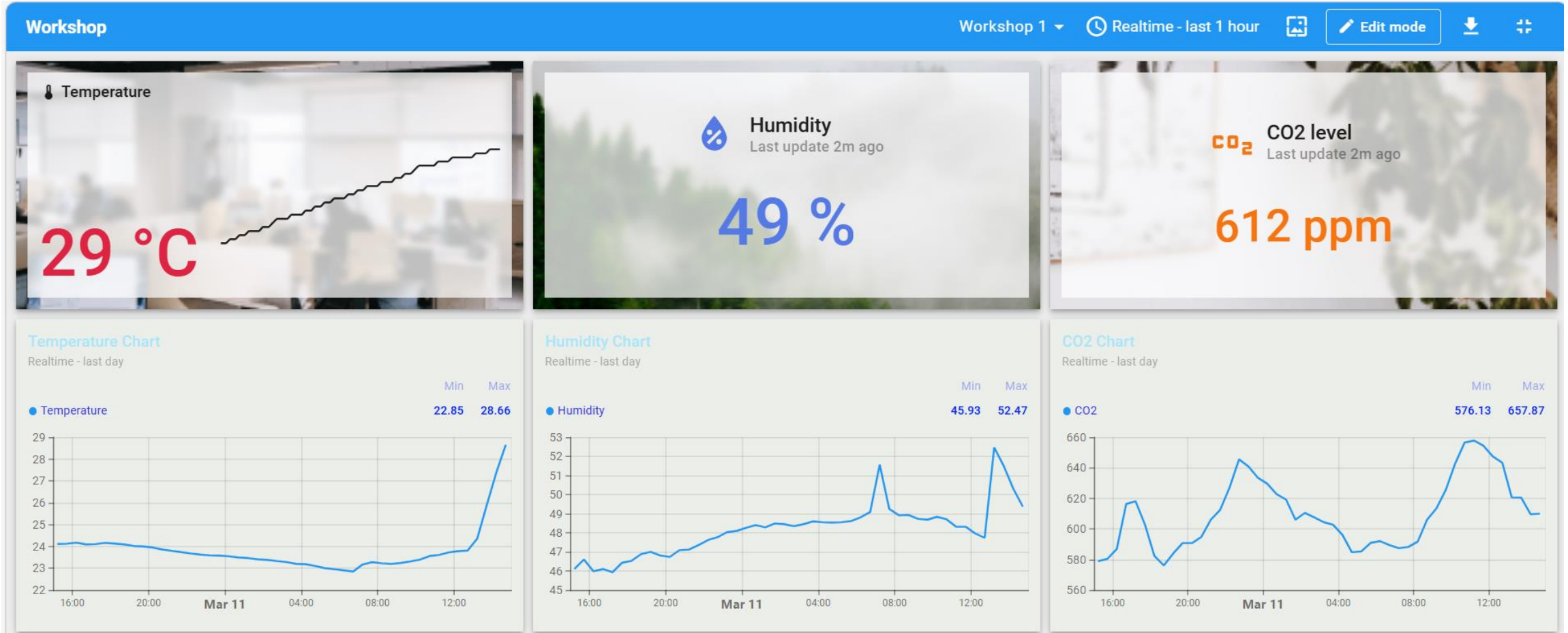

## Live Stream IoT Dashboard

# Q&A

---



**Thank You**